



PXI
CompactPCI
CAN
Industrial Platform
ICT
Functional Test

Version
01.00

September
2006

Power Supply/Load Module R&S®TS-PSU

Four-quadrant source with integrated measurement unit

- ◆ Four-quadrant source
 - Bipolar
 - Useable as a voltage or current source
- ◆ Electronic load simulation of 20 W per channel
- ◆ Two independent, floating channels of up to ± 50 V, 3 A, 50 W and separate sensing per channel
- ◆ Programmable current and voltage limiting
- ◆ Integrated voltage and current measurement unit per channel
- ◆ Output and recording of voltage and current profiles
- ◆ External triggering of source outputs and measurement channels
- ◆ Protection against overvoltage, overcurrent, overtemperature and short-circuits
- ◆ 4-to-1 relay multiplexer for force and sense lines of each channel
- ◆ Access to analog measurement bus via eight bus lines
- ◆ Control via CAN bus
- ◆ Selftest capabilities
- ◆ Use in R&S®CompactTSVP and R&S®PowerTSVP
- ◆ Device driver for LabWindows/CVI
- ◆ Generic test software library (GTSL) in DLL format
- ◆ Integration into enhanced GTSL (EGTSL) test software environment for in-circuit tests



ROHDE & SCHWARZ

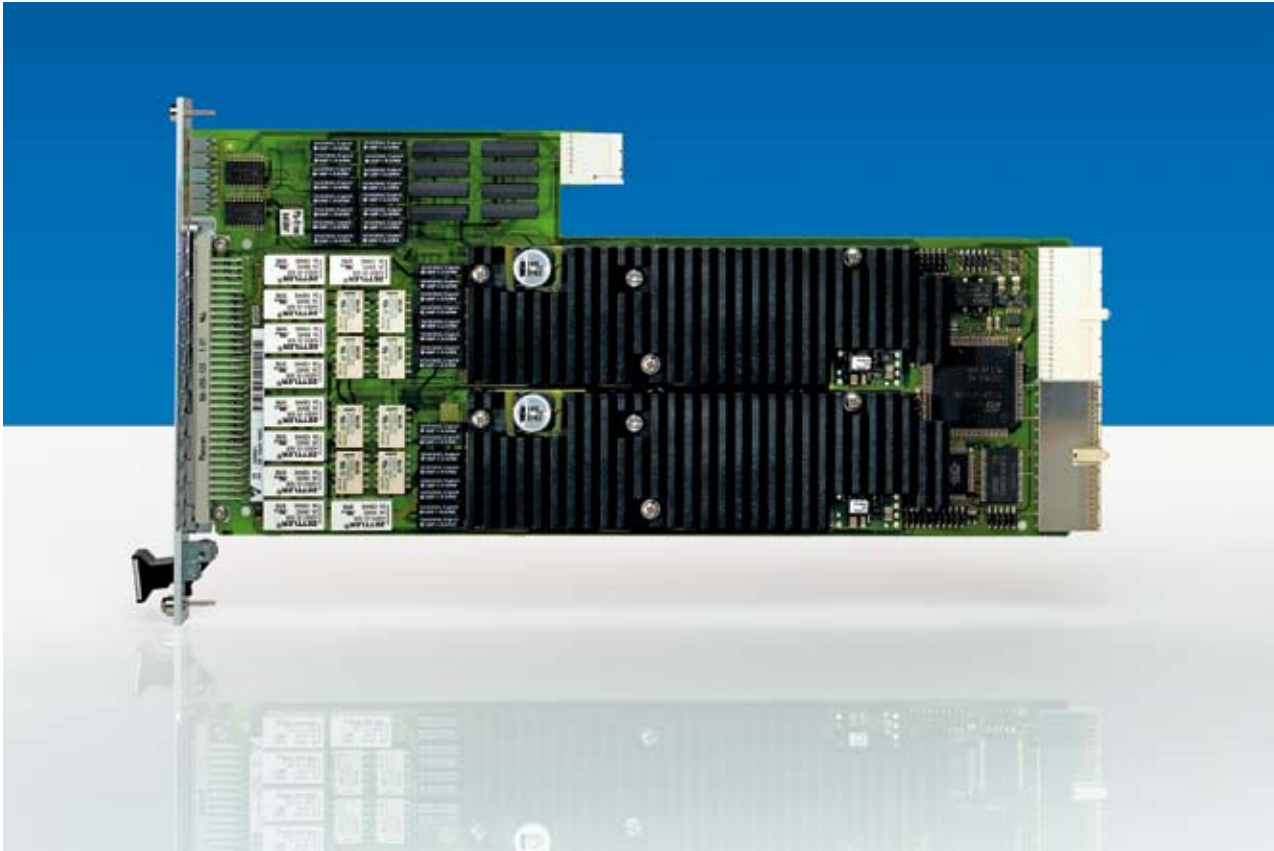

Product introduction

The R&S®TS-PSU is a power supply and load module with two independent, floating channels. Designed for four-quadrant operation, the module can be used in functional tests (FCT) as well as in-circuit tests (ICT). It is controlled via the CAN bus. The R&S®TS-PSU can be used in the R&S®CompactTSVP base unit as well as in the R&S®PowerTSVP. Its innovative technology and versatile functionality make it ideal for applications in the field of automotive electronics.

Due to its special design, the module ensures efficient powering of DUTs while taking up only a single slot.

A measurement unit is integrated in each supply channel. The voltage and current values can thus be read without an external instrument. Voltage drops that may occur on the supply lines can be compensated by external sensing.

Moreover, voltage and current profiles can be output or recorded. The various measurement sources can be monitored via the outputs (CHx_MHI, CHx_MLO) using a fast digitizer (e.g. R&S®TS-PAM).

Integrated 4-to-1 multiplexers are provided for the force and sense lines of each channel, which enables highly versatile signal routing and in many cases eliminates the need for additional switch modules.

In addition, each channel can be switched to four lines of the R&S®CompactTSVP analog bus. Via this bus, the channels can be routed to other measurement and switch modules of the R&S®CompactTSVP without requiring any additional external wiring.

As a four-quadrant source, the R&S®TS-PSU not only acts as a power supply for DUTs but is also capable of electronic load simulation. For example, the R&S®TS-PSU can be used for testing the behavior of automotive control units by applying a defined load to their control outputs.

By external serial cascading of the two output channels, auxiliary voltages of up to 100 V can be generated during in-circuit tests (e.g. for testing Zener diodes or relays). As an additional feature, the output power of the module can be controlled by modulating the pulse width of the output voltage.

The two output channels can be controlled via external trigger signals or internal PXI trigger lines to synchronize them with other instruments. Conversely, each channel can generate trigger events.

The Power Supply/Load Module R&S®TS-PSU is supplied with the following components:

- ◆ **R&S®TS-PSU power module**
Plug-in card to be inserted at the front of the R&S®CompactTSVP or the R&S®PowerTSVP
- ◆ **R&S®TS-PSU RIO module**
Plug-in card to be inserted at the rear of the R&S®CompactTSVP or the R&S®PowerTSVP (behind the R&S®TS-PSU power module, in the same slot)
- ◆ **R&S®TS-PSU AC/DC converter**
External power supply of the R&S®TS-PSU power module (to be connected to the R&S®TS-PSU RIO module)

Typical applications

- ◆ High-performance voltage and current supply in functional tests
- ◆ Recording of current/voltage characteristics of the DUT being powered
- ◆ Electronic load simulation
- ◆ Auxiliary voltage source for in-circuit tests (e.g. up to 100 V for Zener diodes)
- ◆ Charge/discharge tests (e.g. by defined discharging of batteries)

Software support

The Power Supply/Load Module R&S®TS-PSU is supplied with an IVI-compliant LabWindows/CVI driver, which offers control panels and online help as standard features. Alternatively, all functions for configuring the channels and measurement units can be called via the GTSL DC power supply library.

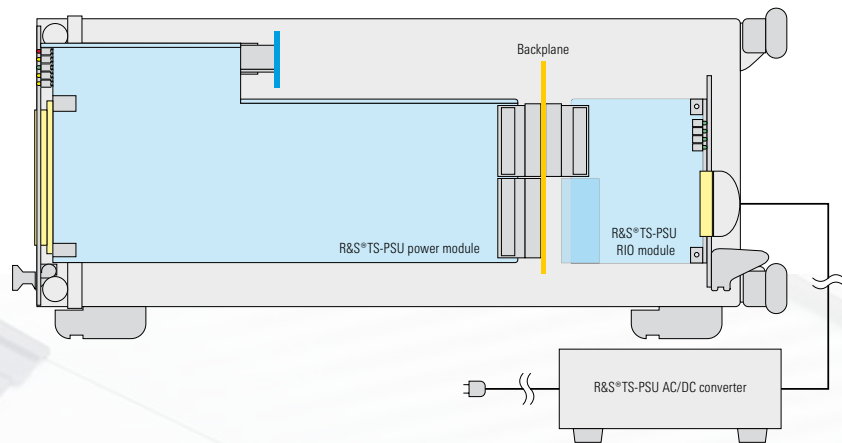

Block diagram of the R&S®TS-PSU components installed in the R&S® CompactTSVP

Selftest and diagnostics for reliable operation

The built-in selftest capability of the module ranges from fast diagnostics to a fully automatic test of all relays and switching paths (requires R&S®TS-PSAM).

Diagnostic LEDs on the front panel make system integration faster and easier. The user can see at a glance whether the module is in proper working order.

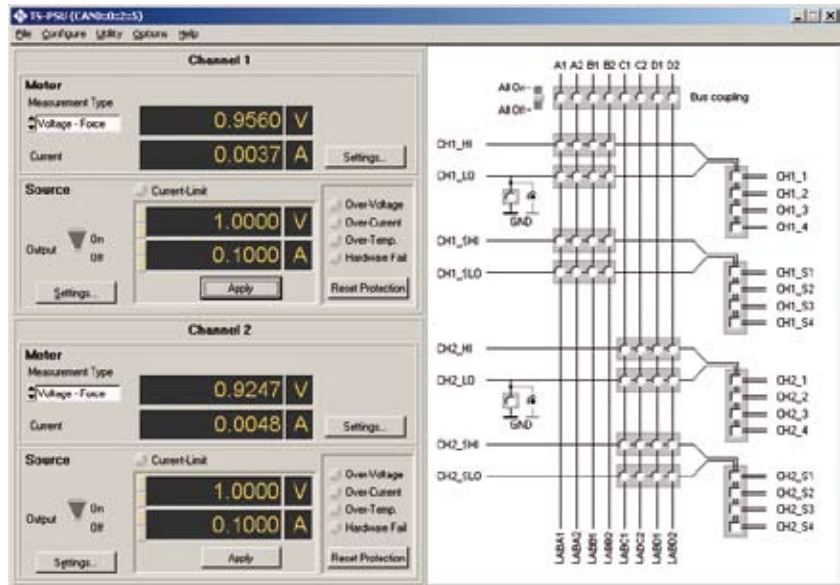

Software control panel for the R&S®TS-PSU

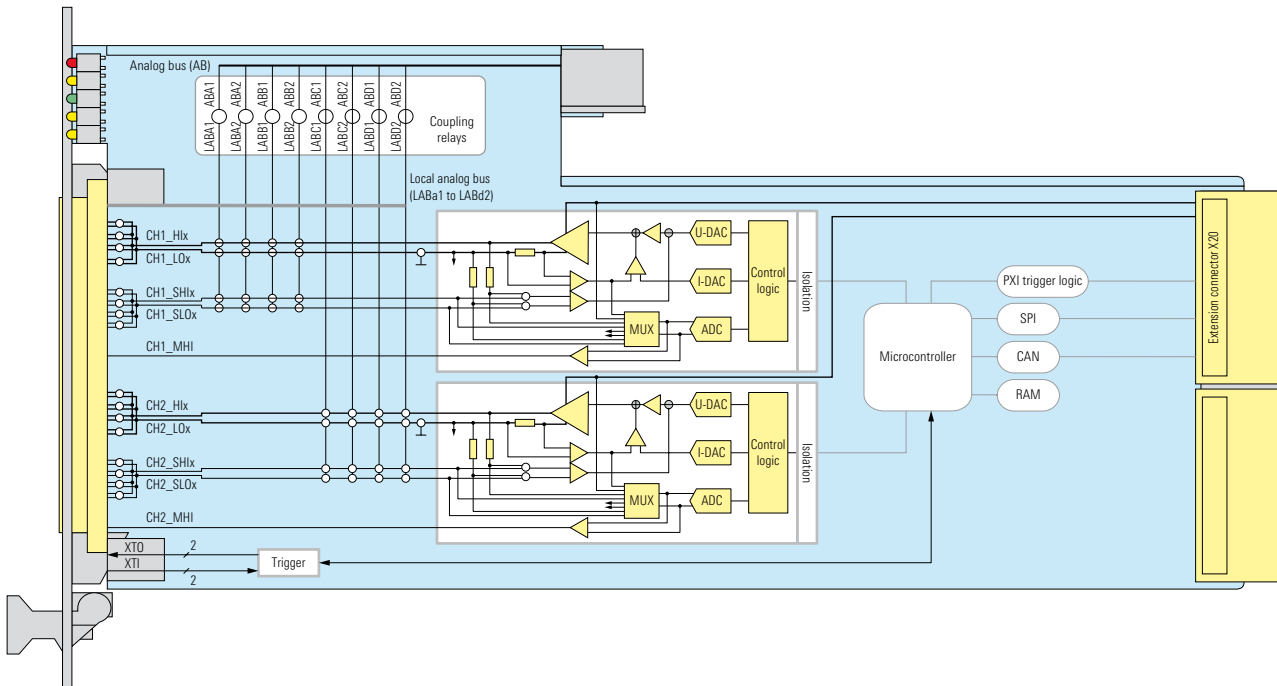

Block diagram of the R&S®TS-PSU power module

Specifications

Use with an R&S®TSVP system platform

R&S®CompactTSVP	1 slot required
R&S®PowerTSVP	1 slot required

Interface

Control bus	CAN 2.0B (1 Mbit/s)
DUT connector (front)	in line with DIN 41612, 96 pins
I/O connector (rear) for R&S®TS-PSU AC/DC converter	D-Sub, 15 pins
Tolerances of specified values apply under the following conditions: Recommended calibration interval Temperature range Additional error indicated by the temperature coefficient in the range ¹⁾	1 year +23 °C ±5 °C +5 °C to +18 °C and +28 °C to +40 °C

Output channels

Number of channels	2 (independent, floating)
Source type	four-quadrant
Max. operating voltage	125 V (signal-to-earth isolation: 750 V)
Max. output power per channel	
Source mode	50 W
Sink mode	20 W
Sampling mode	
Profiles	voltage, current
Sample clock	max. 10 kHz
Memory, voltage profile	10000 samples
Memory, current profile	10000 samples

Output voltage

Type	bipolar
Voltage ranges	±50 V and ±15 V
Resolution	16 bit + sign
Line regulation	0.1 %
Load regulation in external sense mode (10 % to 90 %)	0.1 %
Ripple + noise	typ. 6 mV rms at 20 MHz bandwidth
Settling time (10 % to 90%/90% to 10 %), resistive load only	
Range 10 mA/100 mA	100 µs
Range ≤1.3 A/15 V	100 µs
Range ≤0.4 A/50 V	100 µs
Other ranges	formula: $t = (\Delta V \times 0.32) / (3.5 - I_{\text{actual}})$ ms
Load transient recovery time (10 % to 90 %)	100 µs
Polarity switching time	typ. 200 µs
Recovery time from short	max. 10 ms + settling time
Remote sensing	compensation for 2.0 V per lead

¹⁾ Accuracy: ±(% of set value + absolute value); temperature coefficient: ±(0.1 × accuracy)/°C.

Output current

Type	source/sink
Current ranges	10 mA, 100 mA, 3 A
Resolution (effective bits)	16 bit

Accuracy of DC stimulus unit

	Stimulus range	Resolution	Error limits
Voltage	15 V	230 μ V	0.2% + 15 mV
	50 V	780 μ V	0.2% + 50 mV
Current	10 mA	0.39 μ A	0.4% + 20 μ A
	100 mA	3.7 μ A	0.4% + 200 μ A
	3 A	115 μ A	0.4% + 6 mA

Measurement channels

Type	built-in, one measurement channel per power supply/load channel
Measurement source	voltage, current, external voltage
Voltage range	50 V
Current ranges	10 mA, 100 mA, 3 A
Resolution (effective bits)	16 bit
Sampling mode	
Sample clock	max. 10 kHz
Sample memory	10000 samples

Accuracy of measurement unit

	Measurement range	Resolution	Error limits, average ^{2),3)}	Error limits, sampling mode ^{2),3)}
Voltage	50 V	1.56 mV	0.1% + 50 mV	0.1% + 50 mV
Current	10 mA	0.78 μ A	0.4% + 20 μ A	0.4% + 80 μ A
	100 mA	7.4 μ A	0.4% + 200 μ A	0.4% + 800 μ A
	3 A	230 μ A	0.4% + 6 mA	0.4% + 24 mA

Miscellaneous

Protection	overvoltage, overtemperature, shorted outputs, sense lines shorted or inverted: typ. 5 V voltage rise
Inhibit	electronic ON/OFF within 200 μ s
Pulse-width modulation (PWM)	pulse width \geq 50 μ s, frequency \leq 10 kHz
Remote sensing	switch-selected
Paralleled outputs	not allowed
Cascaded outputs	allowed, external jumper required
Trigger lines	8 PXI, 2 XTI, 2 XTO
Isolation (signal – signal, signal – earth)	125 V DC

²⁾ Accuracy: \pm (% of set value + absolute value); temperature coefficient: \pm (0.1 \times accuracy)/ $^{\circ}$ C.

³⁾ Average of 1000 samples, measuring time 100 ms.

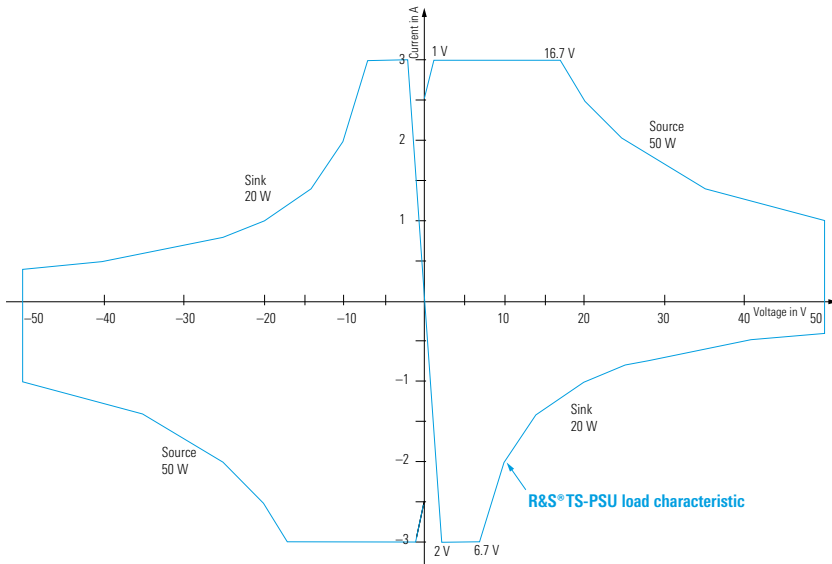

Source/sink characteristics

Analog measurement bus and relay multiplexer

Rohde & Schwarz analog measurement bus	8 lines
Coupling relays	8, local bus to global bus
Switching voltage DC/rms	125 V/90 V
Switching current	max. 1.0 A
Switching power DC/rms	10 W/10 VA
Relay multiplexer	4-to-1 DPST (one for each force and sense channel)
Switching voltage DC/rms	125 V/90 V
Switching current	3.0 A
Switching power DC/rms	60 W/250 VA

General data

Power consumption	max. +5 V/1 A from R&S® CompactTSVP frame, max. 190 W from AC supply via R&S®TS-PSU AC/DC converter
EMC	in line with EMC Directive 89/336/EEC and EMC Standard EN 61326
Safety	CE, EN 61010 Part 1
External power supply	100 V to 240 V AC, 60 Hz to 50 Hz
Mechanical loading	
Vibration test, sinusoidal	5 Hz to 55 Hz: 2 g, in line with MIL-T-28800D, Class 5 55 Hz to 150 Hz: 0.5 g, in line with MIL-T-28800D, Class 5
Vibration test, random	10 Hz to 300 Hz, 1.2 g
Shock test	40 g, in line with MIL-STD-810, Classes 3 and 5
Temperature loading	
Operating temperature range	+5 °C to +40 °C
Permissible temperature range	0 °C to +50 °C
Storage temperature range	-40 °C to +70 °C
Relative humidity	95% at +40 °C
Dimensions (W × H × D)	
R&S®TS-PSU power module	316 mm × 174 mm × 20 mm (12.4 in × 6.8 in × 0.8 in)
R&S®TS-PSU RIO module	130 mm × 128 mm × 20 mm (5.1 in × 5.0 in × 0.8 in)
R&S®TS-PSU AC/DC converter	180 mm × 115 mm × 65 mm (7.1 in × 4.5 in × 2.6 in)

Weight

R&S®TS-PSU power module	0.8 kg (1.76 lb)
R&S®TS-PSU RIO module	0.12 kg (0.27 lb)
R&S®TS-PSU AC/DC converter	1.2 kg (2.65 lb)
Recommended calibration interval	1 year

Ordering information

Designation	Type	Order No.
Power Supply/Load Module	R&S®TS-PSU	1504.4530.02
Open Test Platform R&S®CompactTSVP	R&S®TS-PCA3	1152.2518.02
R&S®PowerTSVP Switching Application Chassis	R&S®TS-PWA3	1157.8043.02



More information at
www.rohde-schwarz.com
(search term: TS-PSU)



www.rohde-schwarz.com

Europe: +49 1805 12 4242, customersupport@rohde-schwarz.com
USA and Canada: +1-888-837-8772, customer.support@rsa.rohde-schwarz.com
Asia: +65 65 130 488, customersupport.asia@rohde-schwarz.com